

# AcquaSaver®

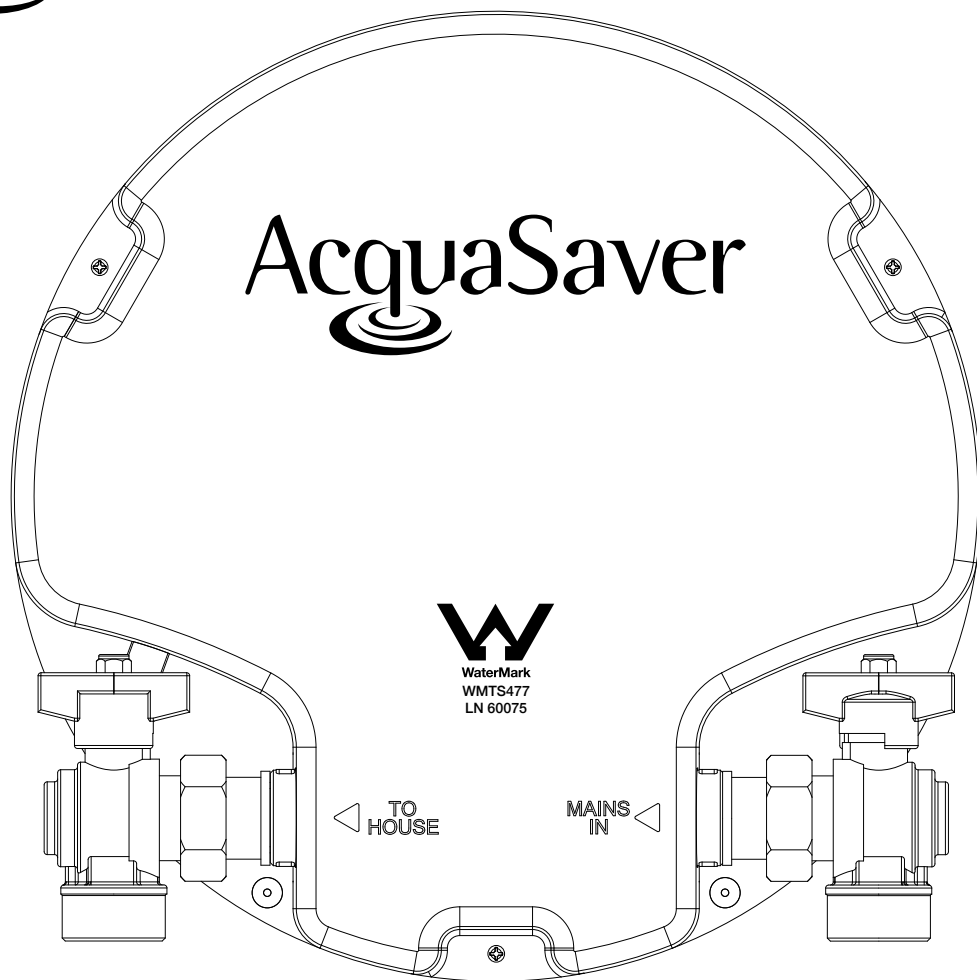

## Top of Tank Assembly

### **ACT20** Installation & Operating Instructions

- ✓ Hydraulically Operated
- ✓ Solid Brass Construction
- ✓ Built-in Dual Check Valves



### Introduction

The AcquaSaver Valve is a fully automatic mechanical rainwater/mains changeover device designed for submersible pressure pump system for harvesting rainwater for the toilet, laundry and household applications with automatic mains water backup.

### Features

- ✓ Patent design
- ✓ Easy to install
- ✓ Watermark Approved
- ✓ 3 year Infield Warranty
- ✓ Does not require regular maintenance
- ✓ No electrical consumption
- ✓ No electrical components
- ✓ Solid brass construction
- ✓ Fully waterproof - Built to last
- ✓ Built-in certified dual check valve for backflow prevention
- ✓ Watermark Approved right angle ball valves

### Specifications

Max Mains Pressure	500 KPa recommended
Max Pump Pressure	600 KPa
Min Pump Pressure	300 KPa Recommended
Max Flow Rate	50 LPM
Max water temperature	40° C
Min Water Temperature	0° C*
Pump Inlet	25mm 1" BSP F
Mains Water Inlet	20mm 3/4" BSP
Outlet	20mm 3/4" BSP
Weight	2.5 Kg

\*Ensure proper protection against freezing weather

### Operation

The AcquaSaver valve will always prioritize the use of rainwater over mains water when rainwater is available and will automatically switch to mains water in the event of the rainwater tank running low or in an electrical failure.

When rainwater has been replenished, or power has been restored to the pump, the AcquaSaver valve will always automatically prioritize back to rainwater.

The pump is only active when rainwater is being drawn from the rainwater tank; it does not operate when the AcquaSaver valve has switched to mains water position.

The pump's controller will start and stop the pump when it detects a demand, for example; flushing a toilet.

The operating mechanism of the AcquaSaver valve is a unique patent design and works by hydraulic water pressure created by the pump to close the mains water inlet, which ensures an extremely reliable mechanism using few moving parts and no electronic components..

### Maintenance

The AcquaSaver valve does not require maintenance; however, there are things you can do to ensure its most reliable operation:

- Cleaning your gutters
- Cleaning the inlet strainer on the rainwater tank

If the valve hasn't changed to mains in a 90-day period, it's advised to switch off power to the pump for 12/24hrs and allow mains water to flow through.

### Connection

STEP 1

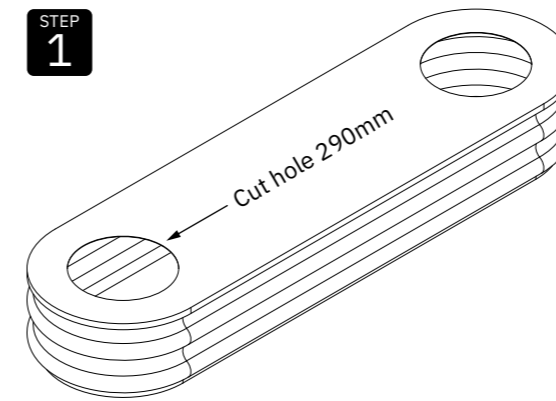

STEP 2

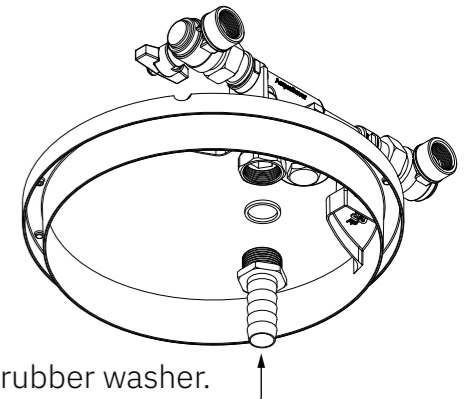

STEP 3

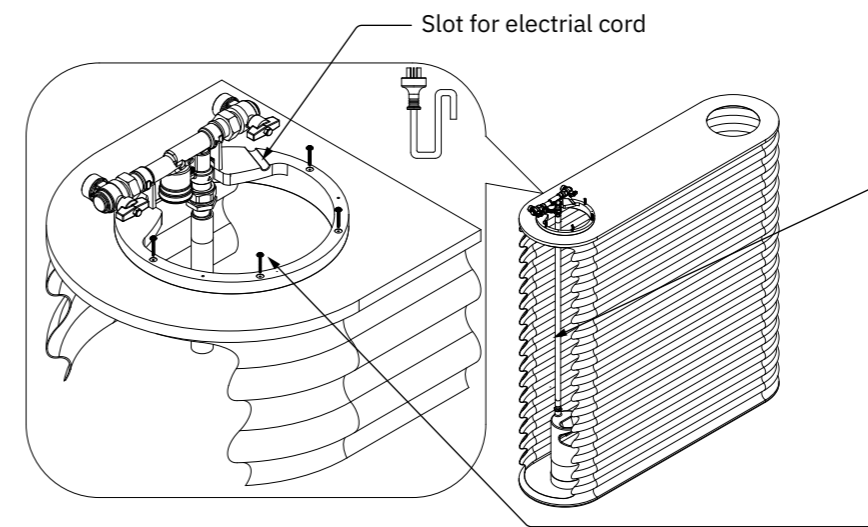

Attach hose to pump and Acquasaver valve.

Screw down Acquasaver tank cover base on to tank. (Screws not supplied)

STEP 4

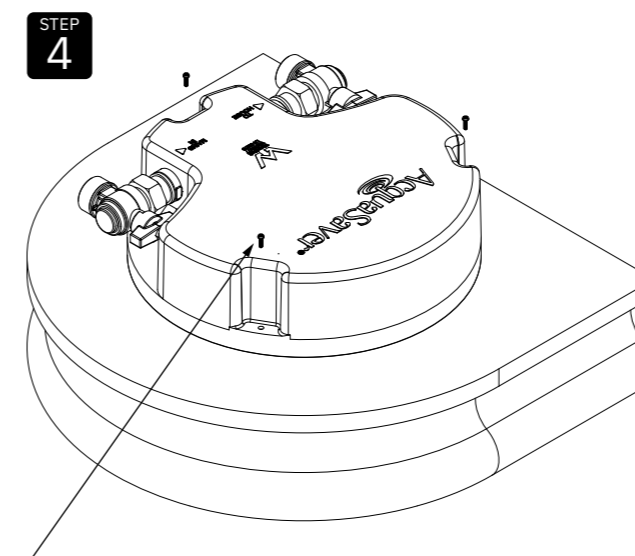

Fit Acquasaver tank cover on to base and use the 3 screws supplied.

STEP 5

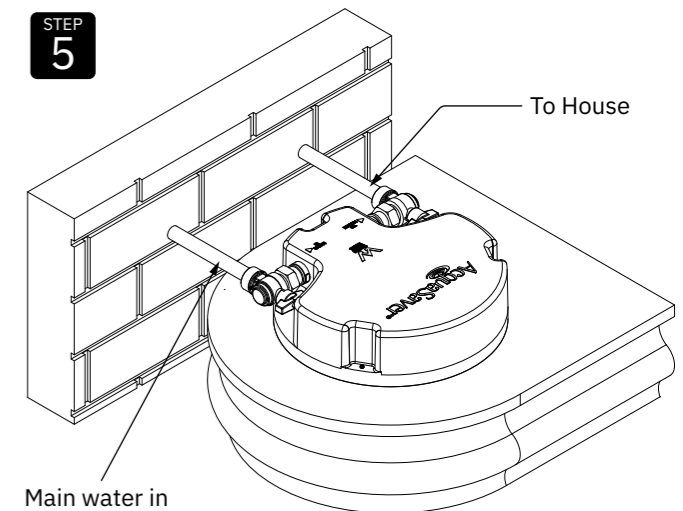

Ensure all joints are locked up correctly.

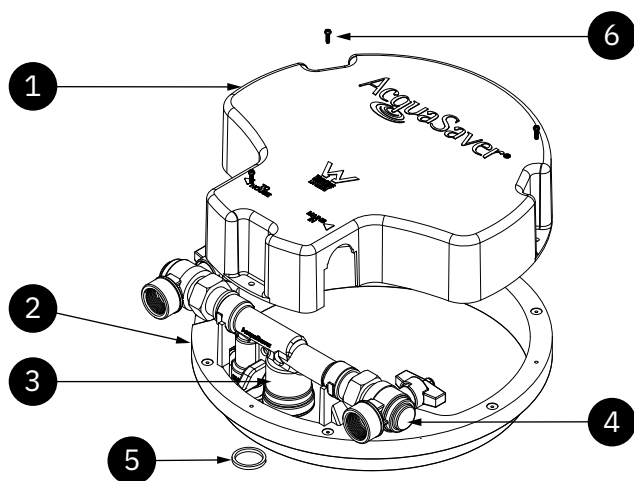

## Parts List

Item No.	QTY	Part Name
1	1	Acquasaver Tank Cover - Top
2	1	Acquasaver Tank Cover - Base
3	1	Acquasaver Valve
4	2	Right Angle Ball Valve (Watermark Approved)
5	1	Rubber Washer
6	3	Plastite Screws

## Trouble Shooting

Symptom	Cause	Remedy
No water is delivered from the pump, or pump performance is decreased.	Rainwater tank is empty. No Power. Isolation valve is closed.	Wait for tank to fill. Check power supply & plug. Open Isolation valve. See pump manual.
No water is delivered from mains.	No water from mains. Debris in the valve.	Check isolation valve Contact dealer.
Pump continually runs.	Leak in the plumbing system. e.g. toilet or tap is leaking. Faulty pump	Contact plumber Contact pump manufacturer.

## AcquaSaver warranty for Australia and New Zealand

As the Supplier for The AcquaSaver Valve, White International has an infield service for material or manufacturing defects, for a period of 3 years from the date of original purchase. Should any part fail as a result of such defects within this period, the AcquaSaver valve will be repaired or replaced free of charge. The AcquaSaver also has a LIMITED LIFETIME WARRANTY on all brass components. Any brass component will be replaced free of charge if it fails in normal use during its life. The warranty applies in all states and territories in Australia and New Zealand. The warranty period commences on the day of the original purchase of the AcquaSaver valve. Evidence of this purchase must be provided when claiming repairs or replacement; it is recommended you retain all receipts.

Both warranties are subject to conditions by the original purchaser with all conditions set in the installation and operating instructions. Failure to comply with these instructions, damage or breakdown caused by fair wear or tear, negligence, misuse, incorrect installation, chemical or additive in the water, corrosive or abrasive water, inadequate conditions, attempting repairs or accidents are not covered by this warranty.

**WHITE INTERNATIONAL PTY LTD**  
60 Ashford Ave Milperra NSW 2214  
PO Box 304 Milperra NSW 2214  
Phone 02 9783 6000  
Customer Service 1300 783 601  
Email Sales: [pumpsales@whiteint.com.au](mailto:pumpsales@whiteint.com.au)  
[www.whiteint.com.au](http://www.whiteint.com.au)

**Please always refer to our website for further technical information & new product innovations**

Disclaimer: Every effort has been made to publish the correct details in this brochure. No responsibility will be taken for errors, omissions or changes in product specifications. Product images are representations only.

© 2023 Copyright White International Pty Ltd

